



**Bobcat**®

**E10**

Compacte graafmachines



**Standaardkenmerken**

710 mm dozerblad / 1100 mm uitgeschoven	Vonkwerende uitlaat
180 mm rubber rupsketting	Stoel met vering
Hulphydrauliek	Tweesnelheden rijversnelling
Controle stand console	* TOPS-kap
Claxon	Bescherming tegen vandalisme
Hydraulisch verbreedbaar onderstel van 710 tot 1100 mm	Werklichten
Oprolbare veiligheidsgordel	Garantie: 12 maanden, 2000 uren

**Gewicht**

Bedrijfgewicht met TOPS-kap	1176 kg
-----------------------------	---------

**Motor**

Merk / Model	Kubota / D722-E2B-BCZ-6 (TIER2)
Brandstof / Koeling	Diesel / Vloeistof
Boring / Slag	67 mm / 68 mm
Maximaal vermogen bij 2000 tpm (ISO 9249)	7,4 kW
Koppel bij 1600 tpm (SAE netto)	39,1 Nm
Aantal cilinders	3
Cilinderinhoud	0,72 l

**Prestaties**

Uitbreekkracht met de lepelsteel	5550 N
Uitbreekkracht met bakcilinder	8294 N
Trekkraft trekstang	9905 N
Gronddruk	29,7 kPa
Rijsnelheid (laag)	2,1 km/h
Rijsnelheid (hoog)	3,1 km/h
Maximale graafdiepte	1820 mm

**Hydraulisch systeem**

Pomptype	Dubbele tandwielpomp
Pompvermogen	2 * 10 l/min bij 2000 TPM
Debiet hulphydrauliek	20 l/min
Ontlastings systeemdruk voor betrokken schakelingen	184 - 192 bar

**Inhoud vloeistoffen**

Koelsysteem	3,0 l
Motorolie en oliefilter	3,5 l
Brandstoftank	16,0 l
Hydraulisch reservoir	2,6 l
Hydraulisch systeem	10,1 l

**Bedieningen**

Besturing	Richting en snelheid bediend door twee met de hand bediende hendels
Hulphydrauliek	Linkerpedaal
Hydraulica	Twee joysticks voor giek, bak, lepelsteel en zwenken bovenstructuur

**Zwenksysteem**

Giek verstelhoek links	70°
Giek verstelhoek rechts	70°
Zwenksnelheid	9 TPM

**Tractie**

Breedte rupskettingen, rubber, standaard	180 mm
Klimvermogen bij omlaag of achteruit rijden op helling	30°

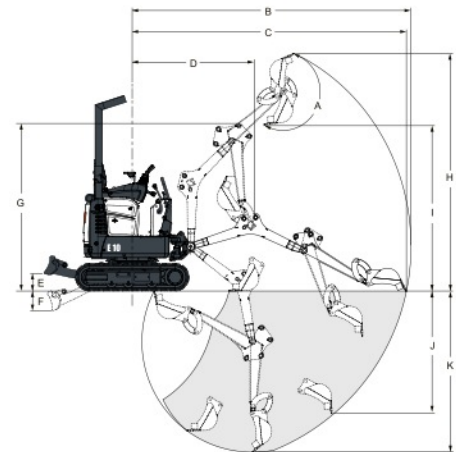
**Werkbereik**

(A)	196°	(E)	196 mm	(I)	1818 mm
(B)	3145 mm	(F)	230 mm	(J)	1383 mm
(C)	3093 mm	(G)	1899 mm	(K)	1820 mm
(D)	1374 mm	(H)	2685 mm		

**Afmetingen**

Alle afmetingen in mm.

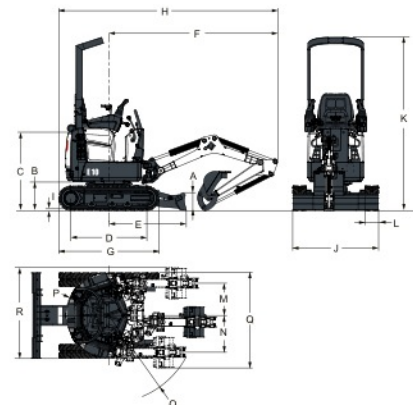

(A)	220 mm	(G)	1280 mm	(M)	413 mm
(B)	363 mm	(H)	2793 mm	(N)	471 mm
(C)	992 mm	(I)	16 mm	(O)	1121 mm
(D)	968 mm	(J)	710 mm	(P)	550 mm
(E)	987 mm	(K)	1100 mm	(Q)	1221 mm
(F)	2153 mm	(L)	180 mm		

**Opties**

Hulpdubbelwerking	Sleutelvrije schakelaar
Waarschuwingsschicht	Bewegingsalarm
Sloopuitrusting	Zwaailicht

**Aanbouwdelen**

Graafbak	Breekhamer
Graadbak	

**Inter-techno b.v.**

Paramariboweg 46  
7333 PB Apeldoorn  
Tel.: +31 555425333 Fax: +31 555426399  
info@intertechno.nl  
www.intertechno.nl



www.bobcat.eu